

"THE QUEEN OF ALL TREES"

Preliminary Notes on the Archaeology of the Olive

HAMISH A. FORBES

LIN FOXHALL

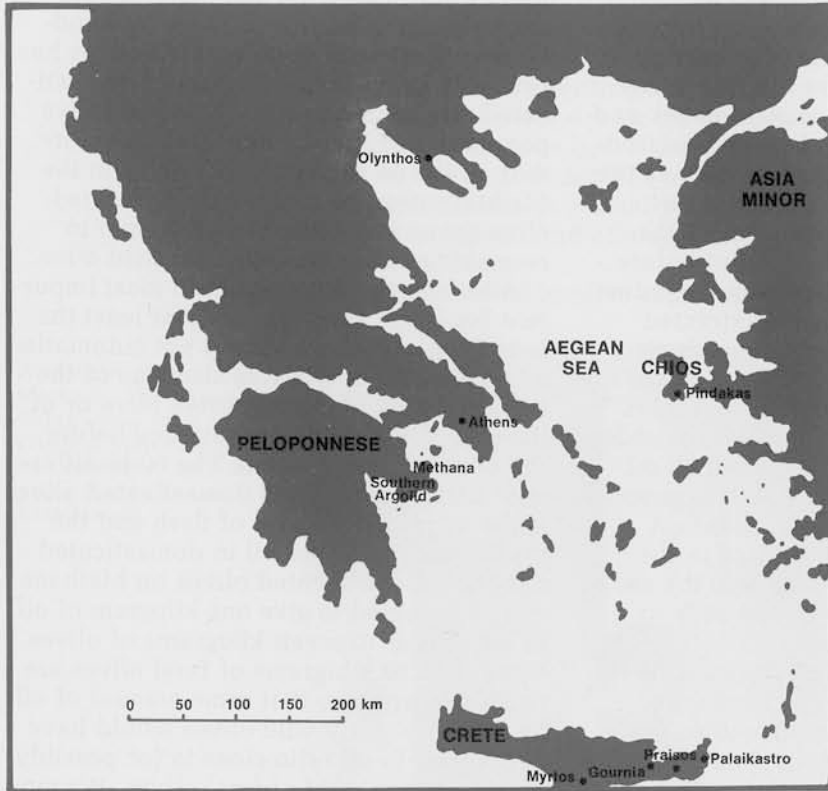

1 Map of Greece showing sites mentioned

A visitor walking through a village in southern Greece early this winter might well hear ominous rumblings coming from the same direction as a pungent, though not unpleasant odor. Following his or her nose, this visitor would arrive at a building where a number of men were gathered, looking on and talking, while others in greasy clothes carried heavy sacks and large metal drums. This is the press building, where olives are turned into oil.

In this building farmers receive the rewards of two years of work and anxious waiting. It is well known that olive trees grow slowly and live to a great age. It is less well known that the olive tree generally only fruits once every two years. The farmer, therefore, spends two years pruning, plowing, fertilizing and hoping for good weather before he gathers his olives. If the two years have been good and there are plenty of olives, the farmer and his family will have a surplus of oil with which to pay for house repairs, increase a



daughter's dowry, or send a child to school. To Greek villagers, olive oil is something without which no meal is complete. But it is much more: "olive oil is gold," they say. It is a savings account in the bank, to be hoarded, speculated with, and liquidated to meet major expenses.

The olive, moreover, is not merely a provider of oil and cash. Each time olives are harvested, the women prepare the larger ones for table olives. Olives cannot be eaten fresh because of the extreme bitterness of the juice. The green ones are therefore soaked in several changes of water and then placed in an earthenware jar to pickle in brine. The olives which have ripened to a black color are nowadays placed in large plastic sacks (clean 50-kilogram fertilizer sacks are very handy) mixed with layers of rock salt. This treatment leaches out the bitter juices and preserves the fruit for up to two years. Pickled olives are an important and nutritious component of the villagers' diet, particularly in the months

when the Greek Orthodox religion prohibits the consumption of all meat, fish and dairy products.

On the peninsula of Methana in the Peloponnese (already described in *Expedition* 19, 1, Fall 1976) a press house is usually a building containing large, electrically-driven machines which contrast starkly with the traditional agricultural methods practiced on the terraced fields of this rugged land. The ethno-archaeologist or ancient historian with an interest in technology is prompted to consider how olive oil was extracted in antiquity. We know from the writings of the ancient Greek and Roman authors that the olive and its products were at least as important then as they are now: Columella, the author of an agricultural manual in Latin, called the olive "the queen of all trees." But before the days of automation, or even the industrial revolution, how was oil extracted from olives? Clear, unambiguous depictions of ancient oil-extraction machines are very few. Moreover, the ancient authors took it for granted that their readers understood the complex process by which oil was extracted, whereas for us it is generally quite unfamiliar. Much important information is therefore omitted in the ancient literary descriptions, and the use of specialized meanings to words adds to difficulties in interpretation.

The archaeological record does little to illuminate the gloom of our ignorance. Many of the parts of olive oil extraction apparatus were of wood that has long since perished, and the few possible parts of stone may be difficult to interpret. In studying the material remains associated with such an important aspect of ancient life in the Mediterranean, the archaeologist has traditionally compared the ancient literary and the excavated evidence. Less often has the archaeologist turned to another closely related field of enquiry: ethnography. And yet, if used carefully, ethnography can put much of the flesh on the bare bones of the archaeological record.

That the olive was important before historical times in Greece is well known. We even have evidence that olives existed in the wild in the Aegean region before the end of the Ice Age. But our knowledge of the origins of olive domestication is very scanty. Part of this problem is caused by the biology of the olive itself. The seed (the hard inner pit, or stone) of the domesticated olive does not produce another domesticated olive. Instead it produces a wild-looking olive. Such an olive is called "feral," as opposed to the genetically pure

"wild" olive. Feral olives are found as "escapes" from cultivation throughout the Mediterranean at present. Because of this phenomenon, olives today, as in antiquity, are propagated by a number of vegetative means, such as grafting and cuttings.

There is no general agreement on the form of the original ancestor of the olive. We prefer the hypothesis that there are no longer any truly wild olives in existence. Rather, the 3000 years and more of bombardment of wild olive flowers by wind-borne pollen from domesticated olives has probably led to the admixture of domesticated olive genes to the whole wild olive population. It is to be expected therefore, that all the so-called "wild" olives in the Mediterranean have some domesticated olive genes and cannot be presumed to resemble exactly the ancestral wild olive.

Although the olive has been most important for its oil since probably at least the Late Bronze Age, we should not automatically assume that this was also true of the earliest forms of domesticated olive or of the wild olives that were gathered before the olive's domestication. The main difference between feral and domesticated olives is the increased amount of flesh and the greater proportion of oil in domesticated varieties. Domesticated olives on Methana can be expected to give one kilogram of oil to every four to seven kilograms of olives. More than 20 kilograms of feral olives are needed to produce that same amount of oil. Presumably, truly wild olives would have had a fruit-to-oil ratio close to (or possibly even less than) that of feral olives. We may assume therefore that the low productivity of wild and early domesticated varieties of olives would have made oil-extraction an unprofitable endeavor, and that they were important primarily as pickled olives. As already noted, the preservation of olives is a simple matter, requiring the minimum of material technology. Salt left by evaporating sea water may have been gathered from rocks near the sea, a practice carried out to this day in the Aegean. The resulting dry salt could have been used to preserve black olives in baskets, as was done until recently in the Mediterranean region. Alternatively, green olives could have been pickled in plain sea water.

To anyone making even the briefest visit to a working press building, with either modern or old-fashioned equipment, it is obvious that the extraction of oil from olives is in complete contrast to the simple technology needed for pickling olives. It is a complex process, demanding relatively sophisticated equipment. There are three

essential stages in oil extraction. First the fruit is crushed. Next the crushed pulp is placed in coarse woven sacks (Fig. 2). A pile of these sacks is then pressed and the liquid, both oil and water, flows through the fabric, leaving the pulp behind. (The flesh of the olive contains 60-75% water and only 6-25% oil). In order to extract more oil after the first pressing, hot water is generally poured over the sacks of pressed pulp and they are pressed again. Finally, the olive oil is separated from the water. Traditionally on Methana this was done in large stone settling tanks, from which the water was drawn off through a stoppered hole at the base. The variety of ways of effecting each stage in the oil extraction process is virtually endless, as the archaeological and ethnographic records indicate.

Equipment used in olive crushing, press-

2
A modern oil press on Methana. The man is filling sacks with crushed pulp ready to be pressed. A hydraulic press stands in the background



2

ing, and oil separation survives from antiquity in differing states of preservation. In examining the various types of apparatus used in the manufacture of olive oil in Greece between the Early Bronze Age and the Late Roman period, we have organized our discussion not chronologically, but in the order of the stages of processing: crushing, pressing and separating. Because in the history of technology new inventions did not always completely replace older ones, the same devices have been used in olive processing in many periods throughout antiquity. Many of these "ancient" kinds of machines were actually in use up into the 20th century; a fact which greatly facilitates our interpretation of the ancient material. There are many reasons for the survival of old technologies in spite of new developments. One reason is general conservatism: farmers are a notoriously conservative group. More specifically, "new-fangled" inventions, even if they are more efficient, can be too complicated to build easily, and too expensive to be affordable. The "latest" equipment may demand a large capital investment, being costly in materials, transport, maintenance and labor, and thus may be impractical and unprofitable for the smaller-scale farmer or businessman. (By analogy, most people would find it foolish to invest in a large tractor to keep up a small home garden).

The archaeological interpretation of crushing, pressing and separating equipment can be very difficult, and has led to many problems in the past. Many archaeological remains are highly ambiguous. For valid identification of a feature as olive processing equipment, it is necessary to be thoroughly familiar with the basic technical processes of oil extraction via both the modern ethnographic sources and the ancient literature. Because excavators have not always been familiar with the techniques of olive processing, a number of remains have been misinterpreted.

The simplest method of crushing olives in antiquity, and still in use in Greece and other parts of the Mediterranean in the recent past, is to spread the fruit out on a hard surface and roll a large cylindrical stone over it. In the Bronze Age, for which we have no evidence for crushing machines like the easily recognizable ones in use in historic times, this is what was probably done. We consider that a stone bench found at the Late Bronze Age site of Palaikastro in Crete would probably have served excellently as a crushing bed of this type. It would probably have been operated by two people, one at each end,

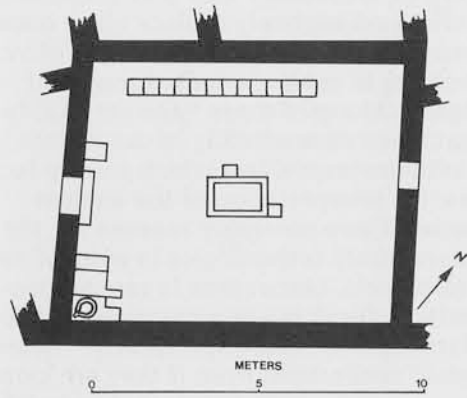

3

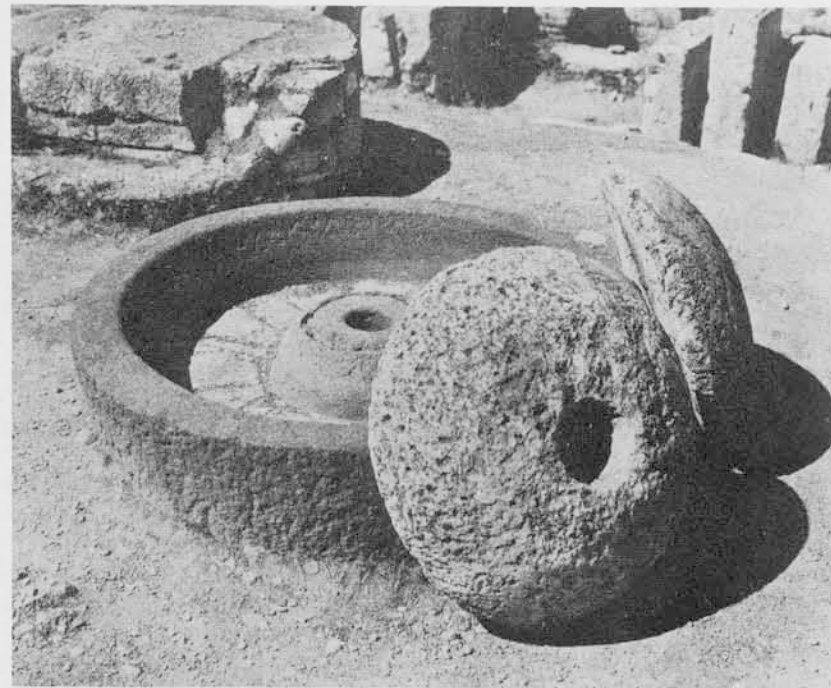

5

3 The pressing room of a Hellenistic house at Praisos, Crete. (After Bosanquet, 1902)

4 Cross sections of stones from ancient Greek olive crushers:

a: Stone from a single-stone crusher, Pindakas, Chios, mid 5th-early 4th centuries B.C. D. 0.82 m.; Th. 0.19 m.; hole 0.12 m. square. (After Boardman 1958-59, p. 304)

b: Stone from a single-stone crusher, Olynthus, Macedonia, *terminus ante quem* 348 B.C. D. 0.80 m.; Th. 0.16 m.; hole 0.14 m. square. (After Robinson and Graham, *Olynthus VIII*, 1938, pl. 82.3)

c: *Orbis* (crushing stone) from a *trapetum*, Villa Rustica, Boscoreale, Italy, *terminus ante quem* A.D. 79. D. 0.89 m.; Th. 0.25 m.; hole 0.14 m. square. (After Drachmann, 1932)

d: *Orbis* from a *trapetum*, Pindakas, Chios, 6th century A.D. D. 0.57 m.; Th. 0.14 m.; hole ca. 0.08 m. square. (After Boardman, 1958-59, p. 304)

5 5th-6th century A.D. *trapetum* (olive crusher) from the Athenian Agora

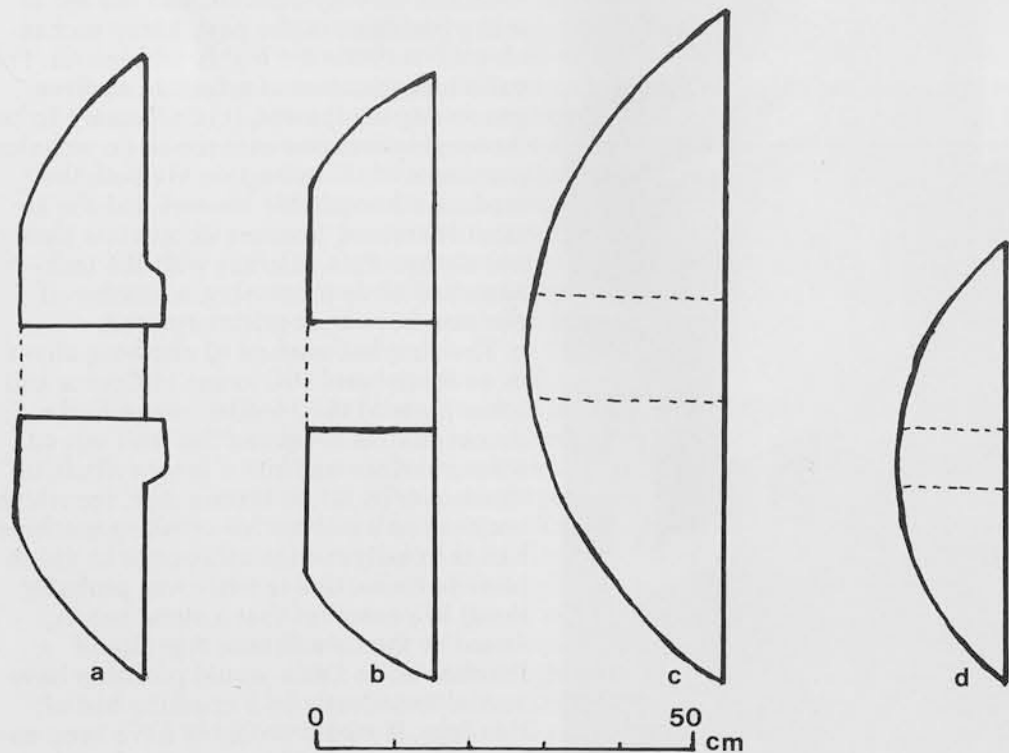

4

pushing the stone roller back and forth between them.

Because this method of olive crushing was so simple and took so little equipment and labor, we find evidence for its use later as well. In the otherwise complete pressing room of a Hellenistic house at Praisos, Crete, a long, low wall, paved with stone slabs on top, almost certainly served as a crushing bed (see Fig. 3), since no other crushing device was found here. It is also unlikely that this low wall would have been placed in the middle of a busy, crowded pressing room unless it had some such important function.

"Proper" crushing machines from historic times are much more easily identifiable, thanks ultimately to the excellent descriptions of them by the Roman agricultural writers Cato and Columella. Here we shall examine two types of crushing machine used in antiquity: the *trapetum*, which used two crushing stones (*orbes*), and the single-stone crusher.

So far, we have not been able to find incontrovertible evidence for the use of the *trapetum* earlier than the Roman period, though during this time it was very popular. The *trapetum* used two crushing stones (*orbes*), matched in size and contained in a large, carefully carved, stone basin (*mortarium*). An axle penetrated the central holes of the *orbes* and was balanced on an up-right support in the middle of the *mortarium*. The stones had to be very carefully balanced to clear the *mortarium* walls. The ancient author Cato suggested that the space between the *orbes* and the *mortarium* be about one Roman *digitus* (about 1.85 cm.). *Trapeta* were in use throughout the Roman period, as the 5th to 6th century A.D. example from the Athenian Agora (Fig. 4) shows, though they went out of fashion after that time.

The earliest evidence for the single-stone crusher consists of a truncated hemispherical stone with a square central hole, found at Pindakas on the island of Chios, dating

6 *Trapetum*: wooden parts reconstructed. (After Drachmann 1932, and K. D. White, 1975, *Farm Equipment of the Roman World*, Cambridge University Press: no scale given)

7 Olive crusher in use in North Africa in the recent past. (After Camps-Fabrer, 1953: no scale given)

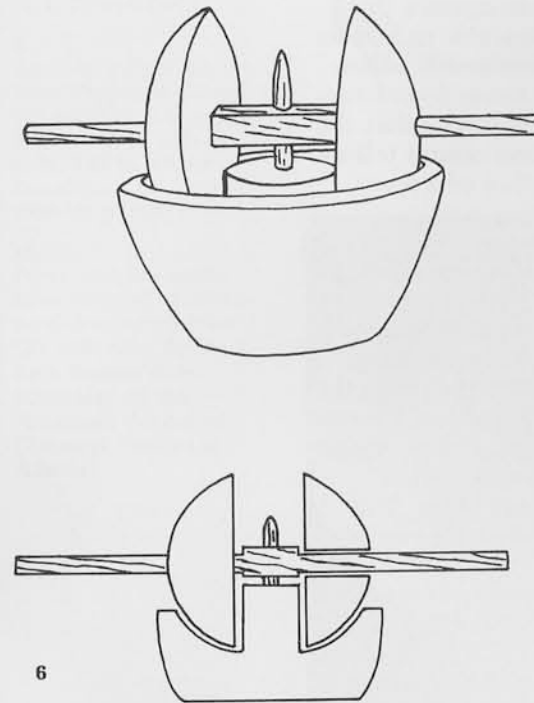

6

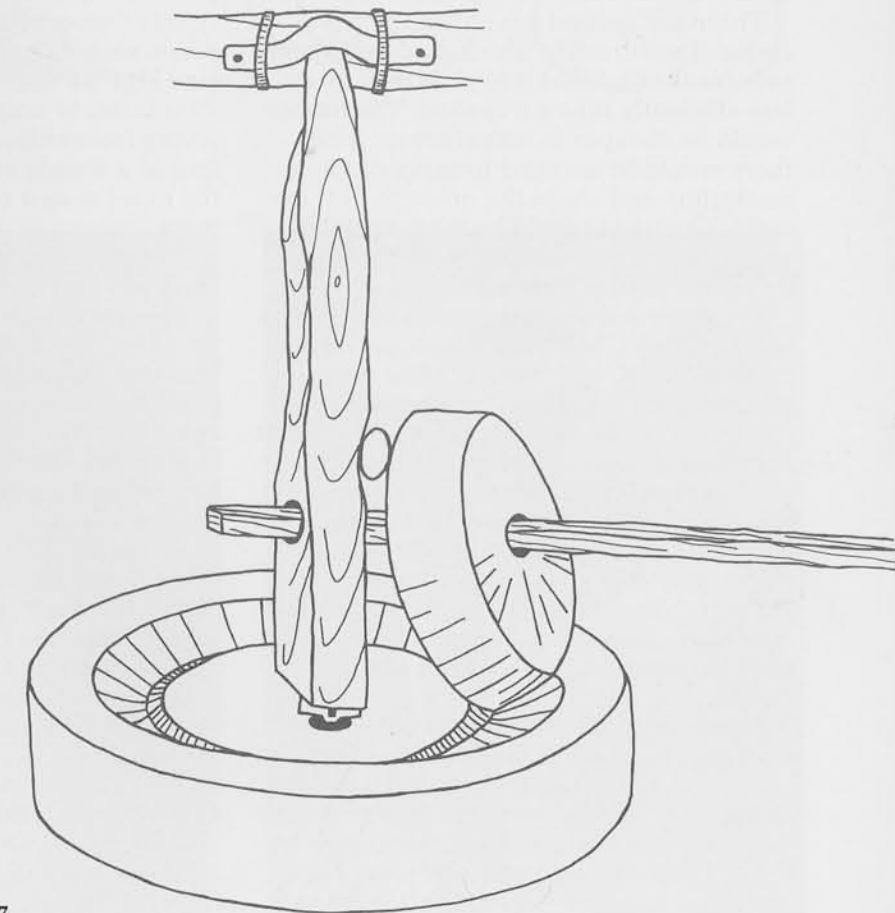

7

between the mid 5th and early 4th centuries B.C. Five similar stones were found at Olynthos in Macedonia, and date to some time before 348 B.C. Previously, these stones have generally been thought to come from *trapeta*. However, there are several major differences between these stones and the crushing stones of a *trapetum*. In Fig. 5, showing the Pindakas and Olynthos stones next to a *trapetum* stone, it is very clear that the former are considerably flattened on both faces, not hemispherical like the *orbis* of a *trapetum*. It would be impossible to use these flattened stones in the *mortarium* of a *trapetum* since so little of the surface would make contact with the olives. Furthermore, the *orbis* of a *trapetum* were made in closely matched pairs, as noted above. No flattened stones have been found in pairs, or were close enough in size to comprise a pair. Hence the conclusion that these stones were used in a type of crusher using a single stone. Reconstructed, the single-stone crusher would probably closely resemble the example in Fig. 7 from North Africa, and still in use there until quite recently. Stones from single-stone crushers have been found in several different areas of Greece, and there is some scanty evidence for their use by the Romans as well.

There are several advantages to the single-stone crusher which could compensate for the fact that it might crush olives less efficiently than a *trapetum*. The former would be cheaper to manufacture, since there would be no need to carve out a *mortarium* and shape the *orbis* to fit it exactly. The parts would be more portable, and it might be easier to remove crushed pulp than from a *trapetum*.

Olive presses are often much less easy to identify than crushers, since so much was made in wood, and there are few unambiguous remains. Surviving elements of presses in the archaeological record are not even by themselves always distinguishable as olive presses. Other industrial processes besides oil-extraction also used presses. Examples of such might include certain stages in textile manufacture, tanning and grape pressing. (This last activity, however, may have sometimes, though not always, used the same presses as were used for olives).

The lever press seems to have been the most popular type in the ancient world; the best surviving ancient representation of such a press can be seen on the 6th century B.C. Athenian black-figure cup shown in Fig. 8. In a working press, the press beam extends out from a wall or is attached to a

crosspiece supported by two uprights. In the black-figure painting, the heap of sacks being pressed on the press bed by the beam is visible, and the mixture of oil and water exuding from the press pours into a large vessel underneath. The simplest possible weighting system to pull down the heavy press beam is used here: boulders pierced and roped onto the beam, with a press room worker for added weight! Boulder weights continued in use long after we have evidence of more sophisticated contraptions. The 6th century A.D. boulder weights from Pindakas shown in Fig. 9 are very similar to those depicted on the 6th century B.C. vase, and were similarly pierced to allow them to be attached to the press beam.

Other methods of exerting pressure on a lever press were also used, as we know from the numerous finds of olive press weight stones. These stones are at present often undatable and have on occasions caused problems in identification. Fig. 10 illustrates two examples made from reused architectural elements from the Athenian Agora which have previously gone unrecognized.

Unfortunately, as we learn from more modern and complete examples of lever presses, the weight stones can take several types of wooden devices to operate the press, such as pulleys, capstans, or screws (see Figs. 11 and 12). The wooden superstructures, of course, are never found surviving from antiquity. This means that the find of a weight stone alone cannot tell us the exact means of operation of a lever press.

The most complete remains of an ancient press are found at Praisos, where an entire pressing room, complete with crushing facilities (see above) and separation apparatus was found (Fig. 13). Here the stone press bed was found in place (but with the spout reversed, facing the wall) on a paved corner area which served as a base. A hole had been left in the southeast wall to receive one end of the press beam. The press weight lies along the southwest wall, immediately beyond the door.

Besides the lever press, various types of screw press were used, particularly during Roman times and later (Figs. 14, 15). Since these types of press were almost entirely of wood, we must rely for our understanding of their operation on the descriptions of the ancient authors and on extrapolation from 19th and early 20th century A.D. examples.

Individual press beds have been found, often out of context, at many sites, dating from the Late Bronze Age through Roman



8

8 Ancient Greek lever press with boulder weights, depicted on a 6th century B.C. Attic black figure skyphos. No dimensions available. (Courtesy Museum of Fine Arts, Boston: H. L. Pierce Fund)

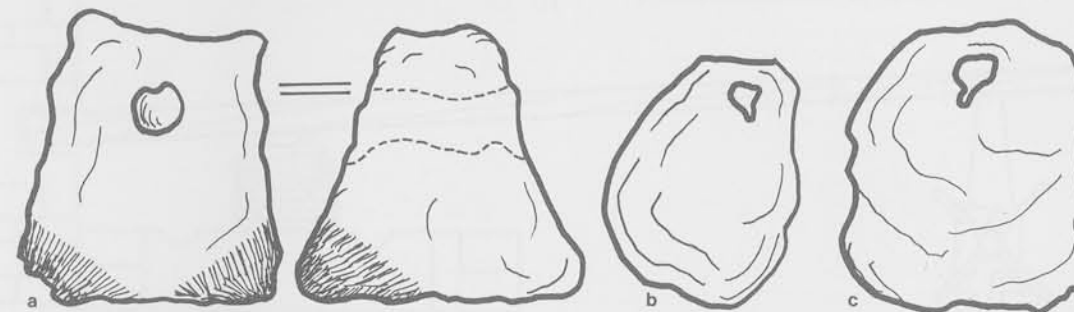

9

9 Boulder weight stones from Pindakas, Chios, 6th century A.D.: a, H. 0.45 m.; b, H. 0.40 m.; c, H. 0.47 m. (After Boardman, BSA 53-54, 1958-59, p. 304)



10



11

10, 11 Press weights made from re-used architectural fragments from the Athenian Agora. Late Roman date. [Courtesy of the American School of Classical Studies at Athens]

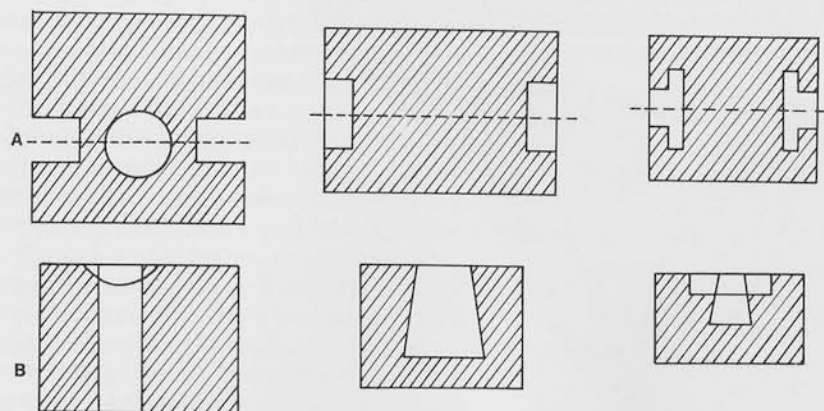

12

12
Two types of olive-press weight: a, top view; b, end view. (After Paton and Myres 1898: no scale given)

13
a, Reconstruction of a Roman capstan-operated lever press. b, Detail of capstan set into weight stone. (Both after Camps-Fabrer, 1953: no scale given)

14
Screw-and-weight lever press in use in Kalymnos in the 19th century A.D. Detail of screw apparatus set into weight stone. (Modified after Paton and Myres 1898: no scale given). Such an apparatus is described by the 1st century A.D. writers, Pliny the Elder and Hero

15
Wooden twin-screw press in use in the recent past in the Southern Argolid. The mechanism closely resembles that described by the 1st century A.D. engineer, Hero. (After N. E. Gavrielides, 1976, *A Study in the Cultural Ecology of an Olive-Growing Community: the Southern Argolid*. Ph.D. dissertation, Indiana University)

16
Wooden single-screw press in use in the recent past in the Southern Argolid. The mechanism closely resembles that described by the 1st century A.D. engineer, Hero. (Same credit as for Fig. 15)

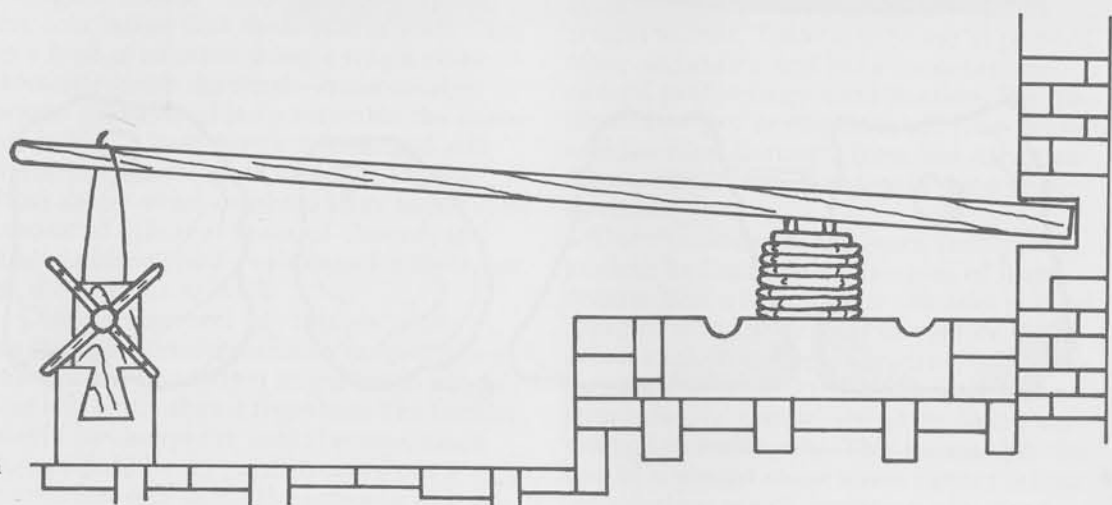

13a

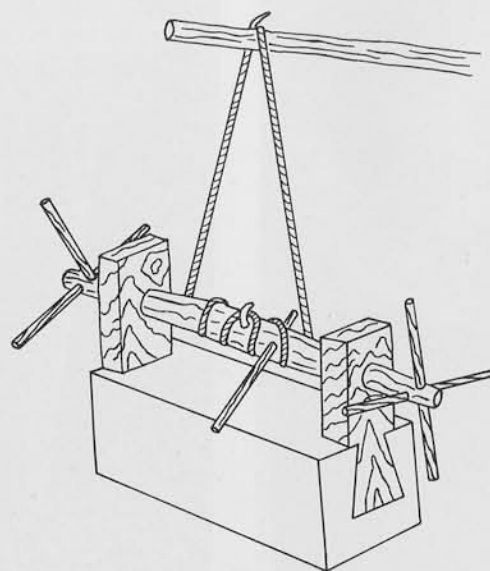

13b

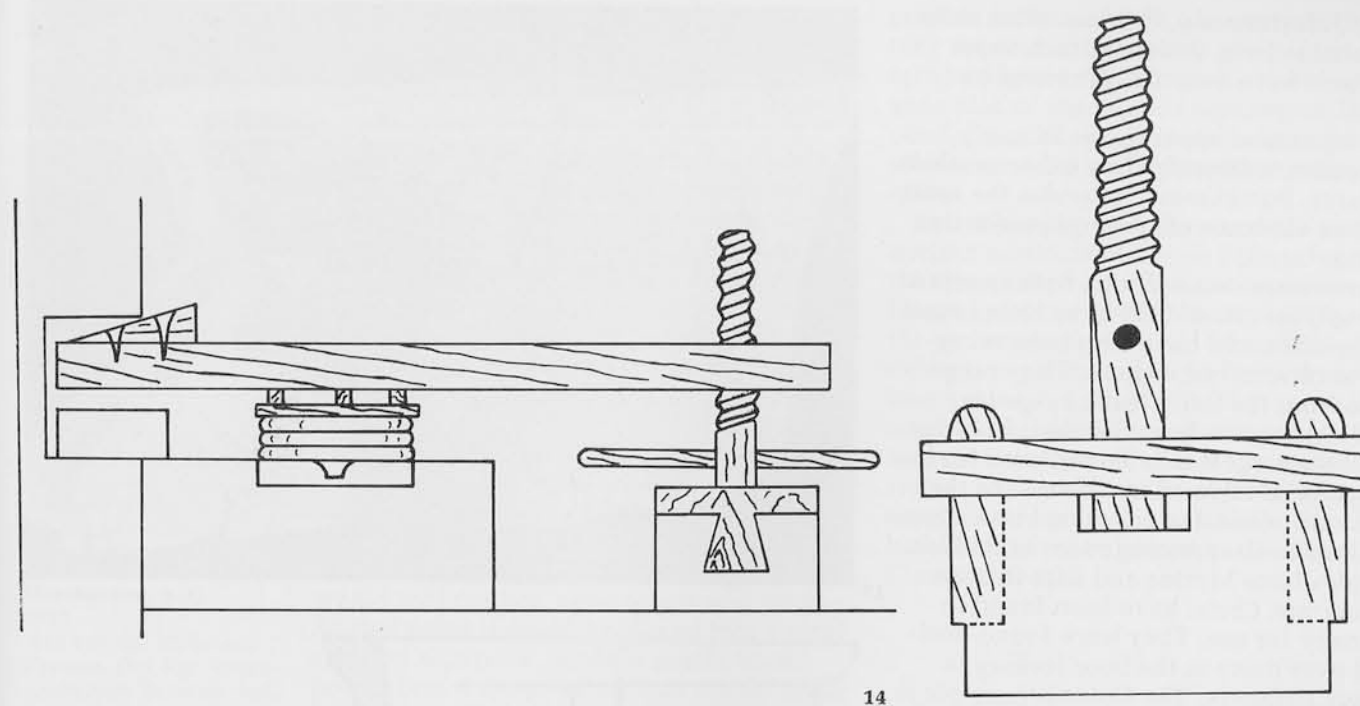

14

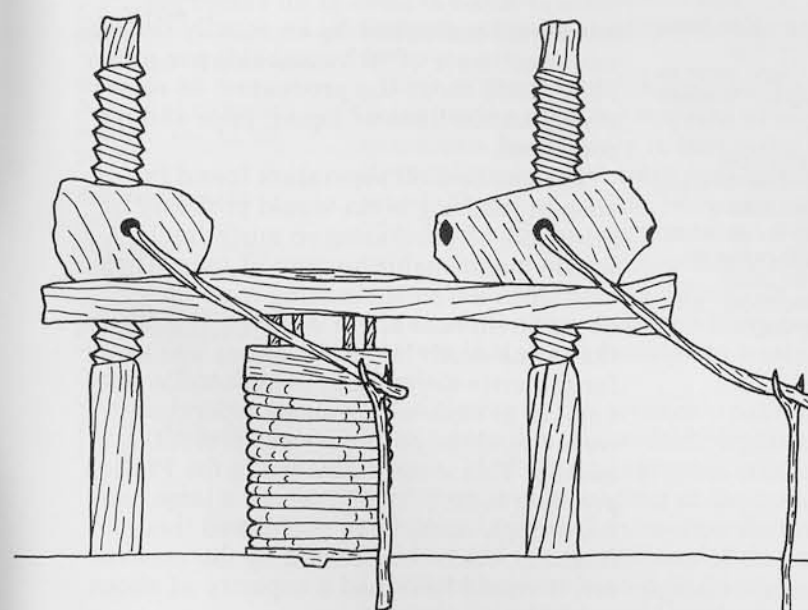

0 50 cm.
15

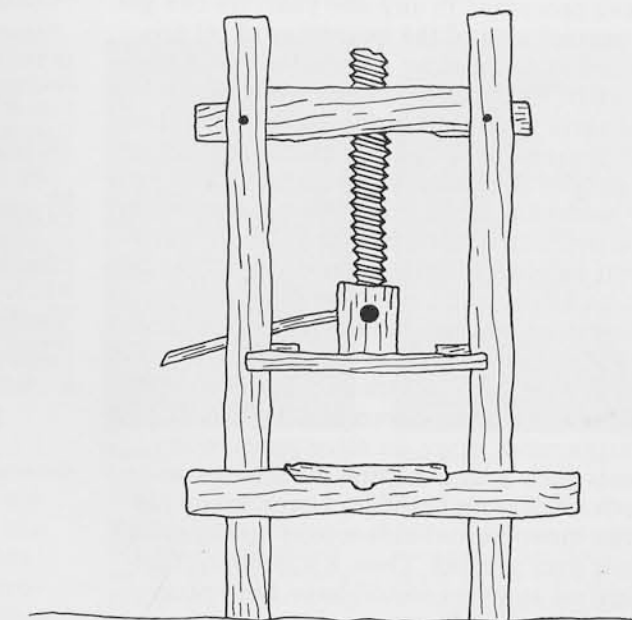

0 50 cm.
16

times. Unfortunately, they are often indistinguishable from drains. In fact, some press beds have been found reused as drains!

Oil separation apparatus is in many cases easier to identify than either crushers or presses. Sometimes it provides the most definitive evidence of olive oil production at a site.

Coarse ware ceramic tubs with spouts at the base (Figs. 16 and 17) have been found at many sites, and have long been recognized as olive oil separators. They range in date from the Early Bronze Age (ca. 2200 B.C.) for one from the site of Myrtos, Crete—the earliest reliable evidence for the production of olive oil in Greece—to the Hellenistic period for one found in a store-room next to the pressing room at Praisos. Examples from Myrtos and Late Bronze Age Gournia, Crete, have been found *in situ*, ready for use. They were found positioned over holes in the floor leading to drainage channels. The Gournia example is now in the University Museum. When mixed oil and water from the press had been left to separate in a spouted tub, the oil could be tapped off into a jar after the water on which it was floating had been let off from the bottom.

It seems unlikely, however, that these spouted tubs constitute the entire separation facility of an ancient pressing room, because they are much too small. Although it is not possible to obtain exact figures on the amount of oil an ancient press would have processed in any one year, we can get a general idea of the quantities of oil produced and stored by comparison with the modern situation. In modern Methana, villagers count on storing 50 liters of olive oil per person per year. This means that a family of four must store about 400 liters of oil for its own consumption, storing oil for two years since the olive tree produces fruit only every other year. Even reducing these figures somewhat for ancient Greece (assuming less productive trees, less efficient presses, etc.) this still indicates that we should think in terms of large quantities of olive oil being stored and produced. Furthermore, since an olive press represents such a large capital investment in both ancient and modern times, many (or even most) households would not have had their own presses. Thus, a number of families' oil supplies would have been processed on a single press.

An ancient press might have produced around 2,500-3,000 liters of oil in an olive producing year. This figure is based on what we consider to be a conservative esti-



17

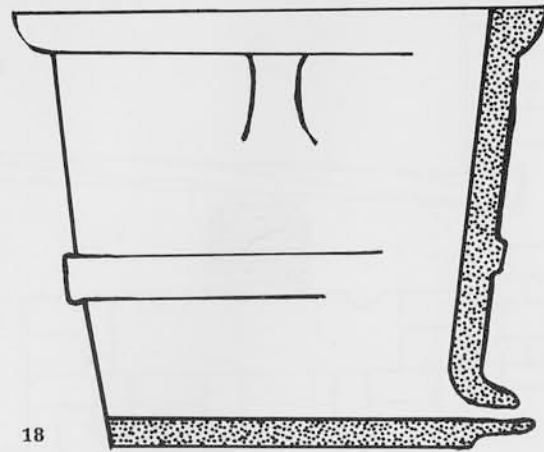

18

17 Pottery separator from Late Bronze Age Gournia, Crete, now in the University Museum

18 Ceramic olive-oil separator from Praisos, Crete, 2nd century B.C. H. 0.5 m.; D. of rim 0.62 m.; approximate capacity 90 liters. (After Bosanquet, *BSA* 8, 1902, p. 268)

mate of 250-300 liters of oil stored per household multiplied by an equally conservative estimate of 10 households per press. This would mean the production of some 10,000-15,000 liters of liquid, juice and oil combined.

The spouted oil separators found in ancient pressing areas would probably be incapable of processing so much liquid within a reasonable amount of time. Their capacities are small, ranging from only about 58 liters to about 90 liters. It is likely that some much larger container was used for the main separation. Significantly, on a number of sites where small separators were found, large tanks were present nearby. This is most obvious in the Praisos pressing room (Fig. 18), where a large central trough could have performed this function. As reconstructed by the excavator, it would have had a capacity of about 630 liters.

The figures for ancient oil production on which our argument is largely based are,

Bibliography

Boardman, John

1959
"Excavations at Pindakas in Chios," *Annual of the British School at Athens*, vols. 53-54, pp. 295-309.

Bosanquet, R. C.

1902
"Excavations at Praisos I," *Annual of the British School at Athens*, vol. 8, pp. 231-270.

Camps-Fabrer, Henriette

1953
L'Olivier et l'Huile dans l'Afrique Romaine. Algiers: Direction de l'Intérieur et des Beaux-Arts.

Drachmann, A. G.

1932
Ancient Oil Mills and Presses. Det Kgl. Videnskabernes Selskab, vol. 1, no. 1.

Forbes, R. J.

1965
Studies in Ancient Technology, vol. III (2nd edition). Leiden: E. J. Brill.

Pansiot, Fernand Paul, and Henri Rebour

1961
Improvement in Olive Cultivation. Rome: Food and Agriculture Organization of the United Nations.

Paton, W. R., and J. L. Myres

1898
"On Some Karian and Hellenic Oil-Presses," *Journal of Hellenic Studies*, vol. 18, pp. 209-217.

Renfrew, Jane M.

1973
Palaeoethnobotany. London: Methuen.

Zohary, Daniel, and Pinhas Spiegel-Roy

"Beginnings of Fruit Growing in the Old World," *Science*, vol. 187, no. 4174, pp. 319-327.

of course, highly speculative, since they include a number of unprovable assumptions. Nevertheless, even if we are only very approximately correct, they still serve to illustrate the large amounts of oil and water to be processed. Besides the archaeological and ethnographic evidence, some support for our argument appears in the writings of the Roman authors Cato and Columella, who both describe facilities in pressing rooms for separating large amounts of liquid.

Therefore, in an ancient pressing room, the oil after pressing would be left to separate from the water and olive juice in a large tank. Then, when the oil had floated to the top, most of it could be ladled out of the tank, or in other cases most of the water could be let out via a channel at the base. The last portions of oil, however, would still contain some water and juice. At that point it could be placed into a small spouted separator for final purification, preventing wastage of oil that would occur by the use of a large tank alone.

These are some of the types of apparatus which made up the complement of a press building in antiquity. Such meager remains as those from the ancient pressing room at Praisos seem at first sight far removed from the gleaming steel, electrically driven crusher, hydraulic press and centrifugal separator in Andonis' press building on Methana. Nevertheless, the olive itself has changed little over the past 3000 years and the basic processes necessary to extract the oil remain the same. Once this is realized, the connections between the ancient press owner's prized possession and that of his modern counterpart come clearly into focus.

One of the main problems for the scholar studying the material remains of olive oil extraction in antiquity is that many parts of the equipment used were constructed in wood. These, of course, have not survived. This is one of the most familiar of the problems that face archaeologists, but here it is exacerbated by the difficulties of identifying and explaining machinery for a process that is not familiar to western scholars.

A solution to the archaeologist's dilemma in this case lies in a multidisciplinary approach. Modern ethnographic studies can lead to an understanding of the complex process of olive oil extraction that is crucial to valid interpretations of the ancient literature and archaeological remains. Also, because "old fashioned" methods and machines often do not disappear with the development of new technologies, ethno-

graphic studies of 19th and early 20th century apparatus frequently provide the archaeologist with complete, working examples of the ancient equipment. Used carefully, ethnography can help to bring otherwise dead and enigmatic ruins to life again.

In attempting to understand life in the ancient world, we have so little information that we cannot afford to cut ourselves off from any of our available sources. By itself, the archaeological record of ancient oil extraction yields only a few rather mysterious stones and sherds. But by carefully combining information gleaned from the ancient literature, archaeology and ethnography, we are able to start building up a recognizable picture of a little known but highly important element in the life of the Classical world.



Hamish A. Forbes took his B.A. in Archaeology and Anthropology at Cambridge University and is a candidate for the Ph.D. in Anthropology at the University of Pennsylvania. His special interest is cultural ecology. He has excavated in England, the United States, Greece and Ireland.



Lin Foxhall received her A.B. in Greek from Bryn Mawr College in 1974. She is presently engaged in graduate study at the University of Pennsylvania, Graduate Group in Ancient History. Her major research interest is ancient agriculture.